

**EROGATORE • SPRINKLER • PISTOLET • LEIMPISTOLE • PISTOLA
ART. 9902 - ART. 0002**

Descrizione • Description • Beschreibungen • Beschreibung • Description	RM.	Art.
Accordo portagomma • Rubber holder connector • Accord porte-gomme • Tüte mit Überweinsauter • Empaïne portagomma	1	10001
Cilindrò dosadora colla • Glue dosating ring • Embout distribution colle • Rindelmutter • Anillo para dosificar la cantidad de cola	2	10002
Cilindrò dosadora colla • Glue dosating ring • Embout distribution colle • Rindelmutter • Anillo para dosificar la cantidad de cola	3	10003
Anello • Ring • Bague • Ring • Anillo CR 117	4	10004
Perno • Pin • Pivot • Hebelbolzen • Eje Ø 6	5	10005
Perno • Pin • Pivot • Hebelbolzen • Eje Ø 5	6	10006
Leva • Levers • Levier • Druckhebel • Palanca	7	10007
Seogger • Seogger ring • Seogger bague • Seoggering • Anillo Seogger Ø 6	8	10008
Impugnatura • Riil • Poignée • Köper • Empuñadura	9	10009
Maniglia • Handle • Mäquille • Abzughebel • Manilla	10	10010
Asta • Rod • Tige • Druckbolzen • Asta	12	10012
Molla • Spring • Ressort • Druckfeder • Muelle	13	10013
Perno • Pin • Pivot • Hebelbolzen • Eje Ø 6	14	10014
Grilletto • Trigger • Détonate • Abzughebel • Gatillo	15	10015
Rondella • Washer • Rondelle • Scheibe • Anillo	16	10016
Seogger • Seogger ring • Seogger bague • Seoggering • Anillo Seogger Ø 6	17	10017
Stelo • Stem • Tige • Ventilspindel • Alina	18	10018
Seogger • Seogger ring • Seogger bague • Seoggering • Anillo Seogger Ø 14	19	10019
Anello • Ring • Bague • Ring • Anillo CR 118	20	10020
Testata spruzzatore • Sprinkler head • Cabose de pistolet • Düsenhaube • Cabeza Pistola	21	10021
Seogger • Seogger ring • Seogger bague • Seoggering • Anillo Seogger Ø 5	22	10022
Cilindrino • Little roll • Petit cylindre • Stül • Cilindro	23	10023
Molla • Spring • Ressort • Feder • Muelle	24	10024
Impugnatura • Riil • Poignée • Spindelkäsung • Empuñadura	25	10026

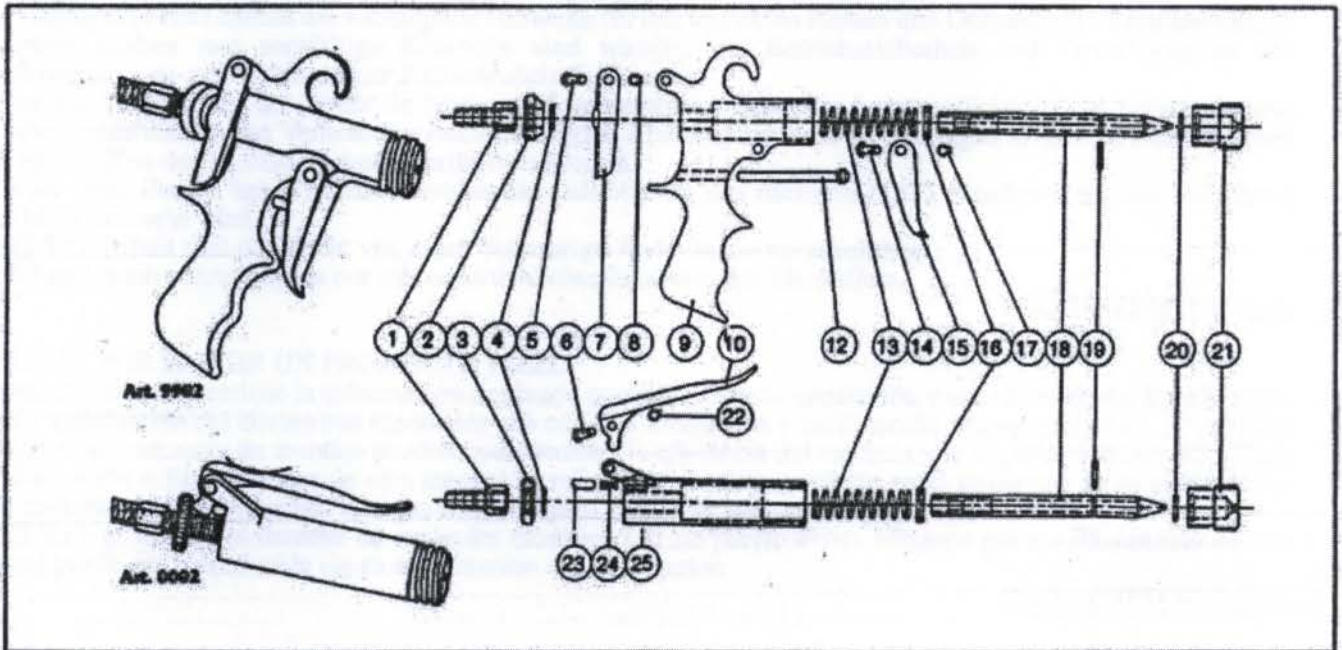
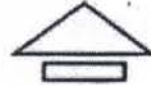

GRAZIE PER AVER SCELTO UN PRODOTTO PIZZI.

Il presente manuale contiene le più importanti informazioni per una corretta installazione ed uso dell'alimentatore. Per l'affidabilità dell'alimentatore e per la sicurezza e la soddisfazione del cliente, è necessario verificare lo stato dell'alimentatore al momento della consegna ed effettuare una corretta installazione. Un controllo non accurato o un errore di montaggio possono compromettere l'efficienza dell'alimentatore e pregiudicare la sicurezza dell'utente. Tutte le informazioni e illustrazioni di questo manuale si riferiscono al modello prodotto al momento di questa pubblicazione. Per eventuali ulteriori informazioni La preghiamo di rivolgersi al più vicino centro di assistenza PIZZI che sarà lieto di aiutarLa. La ditta PIZZI S.r.l. si riserva il diritto di apportare modifiche senza darne alcun preavviso. Nessuna parte o illustrazione di questo manuale possono essere riprodotte senza autorizzazione del costruttore.

PIZZI OFFICINE S.r.l.

CONGRATULATIONS ON HAVING CHOSEN A PIZZI PRODUCT.

This manual contains all the necessary information for proper installation and use of the glue-feeder. It is essential, either for the customer's safety and satisfaction or for good reliability of the feeder, to carry out proper installation and a careful pre-delivery test. A wrong installation or an oversight on testing may compromise the efficiency of the feeder and even jeopardize the customer's safety. All information and illustrations in this handbook refer to the latest produced model at the time of printing. For any further information, please get in touch with the nearest PIZZI service center, they will be pleased to help you any time. PIZZI S.r.l. reserve the right to introduce changes without any prior notice. No part or illustration contained in this handbook can be reproduced without previous approval by the manufacturer.

PIZZI S.r.l. OFFICINE

NOUS VOUS FELICITONS D'AVOIR FAIT L'ACQUISITION D'UN PRODUIT PIZZI.

Ce manuel vous apportera une connaissance de base des caractéristiques, de l'installation et du fonctionnement pour le meilleur emploi du distributeur. Pour garantir la sécurité, la satisfaction du client et la fiabilité du distributeur, il est essentiel que l'installation et l'entretien après la livraison sont correctement effectués. Une erreur ou une négligence pendant le montage ou l'entretien pourraient déterminer un mauvais fonctionnement du distributeur et porter préjudice au client. Toutes les informations et les illustrations présentées dans ce manuel se rapportent au modèle produit au moment de cette publication. Pour d'autres questions concernant le fonctionnement ou l'entretien du produit, veuillez consulter le centre d'assistance PIZZI le plus proche. PIZZI S.r.l. se réserve le droit d'apporter des modifications sans avis préalable. Aucune partie ou illustration de ce manuel ne peut être reproduite sans autorisation du producteur.

PIZZI OFFICINE S.r.l.

WIR DANKEN IHNEN, DASS SIE EIN PIZZI PRODUKT GEWÄHLT HABEN.

Das vorliegende Heft enthält die wichtigsten Hinweise für den korrekten Einbau und Gebrauch des Druckbehälters. Korrekter Einbau und sorgfältige Kontrolle sind wichtig, um Betriebssicherheit und Zuverlässigkeit des Druckbehälters zu gewährleisten zur Zufriedenheit des Kunden.

Mangelnde Sorgfalt bei der Kontrolle oder ein Montagefehler können die Leistungsfähigkeit des Druckbehälters und die Sicherheit für den Verbraucher beeinträchtigen. Alle Angaben und Abbildungen in diesem Heft beziehen sich auf die Zeit der Veröffentlichung verfügbare Modell.

Falls Sie noch Fragen haben sollten, wenden Sie sich bitte an den nächsten PIZZI Kundendienst, wo man Ihnen gern behilflich sein wird.

PIZZI S.r.l. behält sich das Recht vor, ohne Voranzeige Änderungen vorzunehmen.

Nachdruck, auch auszugsweise nur mit ausdrücklicher Erlaubnis des Herstellers.

PIZZI OFFICINE S.r.l.

GRACIAS POR ELEGIR UN PRODUCTO PIZZI.

El presente manual contiene la información necesaria para una correcta instalación y uso del calderín. Para la seguridad y satisfacción del cliente son esenciales una correcta instalación y verificación después del envío. Un control no adecuado o un error de montaje pueden comprometer la eficiencia del calderín y la seguridad del usuario. Toda la información e ilustraciones de este manual se refieren al modelo existente en el momento de su publicación. Para cualquier otra información le rogamos se dirija al centro de asistencia PIZZI más cercano.

PIZZI S.r.l. se reserva el derecho de cualquier modificación sin previo aviso. Ninguna parte o ilustración de este manual puede ser reproducida sin su autorización del constructor.

PIZZI OFFICINE S.r.l.

PIZZI S.r.l. Officine guarantees that the equipment has been tested and approved in their workshops. The guarantee period is limited to 6 months from delivery date, in compliance with the enclosed instructions. The customer is only entitled to the replacement of parts found to be faulty, providing that the faults or breakdowns have not been caused by modifications with the equipment. Eventual claims are considered only if presented in writing within 8 (eight) days from the date of receipt.

It is essential that the instructions in the manual should be carefully followed in order to obtain best results from the equipment and to ensure the maximum duration of all parts.

1 - GENERAL INFORMATION AND INDICATIONS ABOUT THE PRODUCT

Pneumatic feeder in painted steel for vinyl glues - A 8.

1-1 IDENTIFICATION OF THE EQUIPMENT

Portable feeder, with pneumatic delivery for vinyl glues

It is rechargeable and works independently from connections to pneumatic systems.

It does not need any electrical connection.

1-2 DELIVERY

The glue feeder is delivered with all parts assembled, without glue and not under pressure, together with a gun holder and support to screw to the tank.

It is packed in a cardboard box, total weight of 14 Kg.

Dimension: cm. 20 x 20 x 65 h.

2 - USAGE

The pneumatic feeder works with all kinds of vinyl glues and it has been developed for professional use only.

2-1 GLUES

Use only vinyl glues with the density and purpose suggested by the producer.

The machine works perfectly using vinyl glues with viscosity Brookfield 9500 m Pa.s.

**FOR ANY OTHER USE, DIFFERENT FROM THE ABOVE
MENTIONED, THE SOCIETY PIZZI S.r.l. OFFICINE
DECLINES ANY RESPONSIBILITY**

3 - DESCRIPTION - TECHNICAL CHARACTERISTICS

3-1 THE FEEDER

consists of a welded steel tank (Ref. 47), coated externally with epossidic paint. The internal surface is coated in PVC, the bottom is manufactured of thick mopen, to avoid metal fatigue. To seal the tank hermetically, screw the handle (Ref. 30) on the cover (Ref. 40) which is provided with the relevant gasket (Ref. 41). The handle is provided with a central screw (Ref. 30) in chrome steel incorporated in the fastening stirrup (Ref. 31).

Elements on the cover:

- radial manometer (Ref. 39) - 0 - 10 bar which indicates the pressure;
 - relief valve (Ref. 33) calibrated to 5/6 bar;
 - air inlet valve with closing hand screw (Ref. 37);
 - connection with 3 outlets connected with a suction pipe (Ref. 42) and filter (Ref. 43);
- On the sides of the tank, one or more supports (Ref. 49) with removable gun holders (Ref. 48) can be attached.

3-2 GLUE GUNS (MOD. 0002 - MOD. 9902)

for vinyl glues are connected to the feeder through a pipe manufactured of transparent PVC diam. 10 x 16 mm length mt 4 and consists of:

- a PVC handle for Mod. 0002 and an aluminium handle for mod. 9902 (Ref 10) to deliver the glue;
- a glue spreading ring (Ref. 2 or 3) to regulate the quantity of glue;
- a front head of brass to which the nozzles are screwed;
- a rubber holder connector and a central stem of brass.

3-3 ACCESSORIES

The pneumatic glue feeders are equipped with a wide range of standard accessories, all in aluminium with a connector in nylon or in aluminium on request. Upon demand, special accessories can be manufactured, which can be applied to existing systems.

4 - SAFETY RULES AND WARNINGS

- The pneumatic system must have max 8 bar pressure.
If the system is fed by a higher pressure, connect to it a reducing valve in order to obtain the requested pressure.
- Use only vinyl glues with the density and purpose suggested by the producer.
- Before opening the cover, always ensure that the manometer indicates 0 bar and for safety reasons also open the air inlet valve (Ref. 37).

- Avoid placing the feeder close to sources of heat or flame.
- Avoid using the feeder at very low atmospheric temperatures.
- Avoid damaging the feeder as this could cause cracks in the tank and affect working order of the equipment.
- Always keep the feeders in a vertical position.
- Do not disassemble guns, manometer and the relief valve.
- Do not clean the guns with solvents.
- To prevent glue from drying in the nozzles when not in use, place them in water, and after use wash them under a tap or with the help of the connector Ref. 0044.
- Remove, when necessary, the coat of glue from the gun's head.
- To prevent glue from drying inside the tank, the manometer must indicate at least 1 bar.

To ensure a long working life from the machine, it is important to use only PIZZI nozzles and accessories.

PIZZI S.r.l. OFFICINE IS NOT RESPONSIBLE
FOR ANY DAMAGE CAUSED BY NON-COMPLIANCE WITH
THE ABOVE-MENTIONED INSTRUCTIONS

PIZZI S.r.l. Officine does not take any responsibility for any modifications or changes made to the original PIZZI equipment.

5 - INSTRUCTIONS

5-1 PRECAUTIONS BEFORE USE OF THE EQUIPMENT

- * Ensure that the feeder is not under pressure, check that the manometer indicates 0 bar and open the air inlet valve fully (Ref. 37).
- * The system for compressed air must have maximum 8 bar. If it is fed by a higher pressure, connect it to a pressure reducing valve.
- * Use only vinyl glues according with the density and purpose suggested by the producer.

5-2 USE

- * Take the cover (40) off, unscrewing the handle (30) and ensure that the gasket is in the correct place.
- * Take the container of polyethylene (46) out of the tank. Fill it with the relevant glue and place it back into the tank.

- * Replace the cover closing the handle (we suggest that the cover is replaced with the manometer directed towards the side marked by a label).
- * Close the air inlet valve (37).
- * Connect the compressed air to the air inlet valve (37) and slowly open the air inlet valve.
- * Close the air inlet valve when the manometer indicates 5 bar. The pressure must not be higher than 5 bar. If the pressure is higher, a special relief valve (33) opens and the excess air is released.
- * Remove the compressed air pipe.
- * Fill the gun's holder (48) with a small amount of water.

Now the equipment is ready to be used

During use, the manometer will indicate a progressively lower pressure, nevertheless the glue delivery is guaranteed even with minimum pressure of 1 bar.
The glue spreads by pressing the handle (10) and stops upon releasing it.
The delivered glue quantity can be regulated by the ring (Ref. 2 or 3) on the guns.

5-3 WHEN THE EQUIPMENT IS NOT IN USE

During work-breaks, put the gun with nozzle into the holder (48) or the nozzles in a basin with a small amount of water, in order to prevent the glue from drying in the gun assembly.

After use, carefully wash the nozzle in running water or with the help of the tap connector Mod. 0044. If glue is inside the feeder, to prevent it from drying, ensure that the pressure does not drop below 1 bar.

If the feeder has not been used for a long time, we suggest to fill the polyethylene container (46) with warm water, put the feeder under pressure and press the guns handle, to permit water to clean pipe and gun.

Pay attention to the fact that the pressure will make water spray out of the gun.

5-4 REFILLING

For refilling, follow the above-mentioned instructions, taking care to wash the polyethylene container (46), the gasket (41) and the filter (43) with water.

6 - PERIODICAL MAINTENANCE

- * Periodically replace the gasket (41) in the cover.
- * Ensure that the relief valve (33) is not blocked with dried glue.

- * Ensure that the base of the feeder is not damaged or cracked which can be caused by humidity or water.

7 - POSSIBLE WORKING PROBLEMS

- * in case of loss of air from the cover, control that the gasket (41) is not damaged, cut or dirty.
- * In case of glue fattening, because of ageing, we advise to change the glue by washing the equipment with water (we remind that water must be disposed following the normes in force).
- * The guns, that after being washed, leak glue, when not being used, must be replaced or get repaired by a qualified technician.

8- DISPOSAL

In case of disposal, release the air, take the cover off, remove the glue and carry out the elimination according to the directives in force in the country where used.

EC DECLARATION OF CONFORMITY

THE MANUFACTURER

PIZZI OFFICINE S.r.l.
Regione Torame - 13011 BORGOSIESIA (VC)
ITALIA

hereby declares that the equipment:

Pneumatic feeders for the application of glues - A8 range:
MOD. 9000-9001-9002-9003-9004-9005-9006

are in conformity with all the relevant provisions of the EEC (EC)
directive and amendments and with the hereafter mentioned
harmonised standards:

EN 292/1
EN 292/2
EN 294
EN 349

BORGOSIESIA, PURCHASING INVOICE DATE

PIZZI OFFICINE S.r.l.

UMBERTO PIZZI

